

EXAMPLE:
Component Parts (Small #)
Are Included When Ordering
The Assembly (Large #).

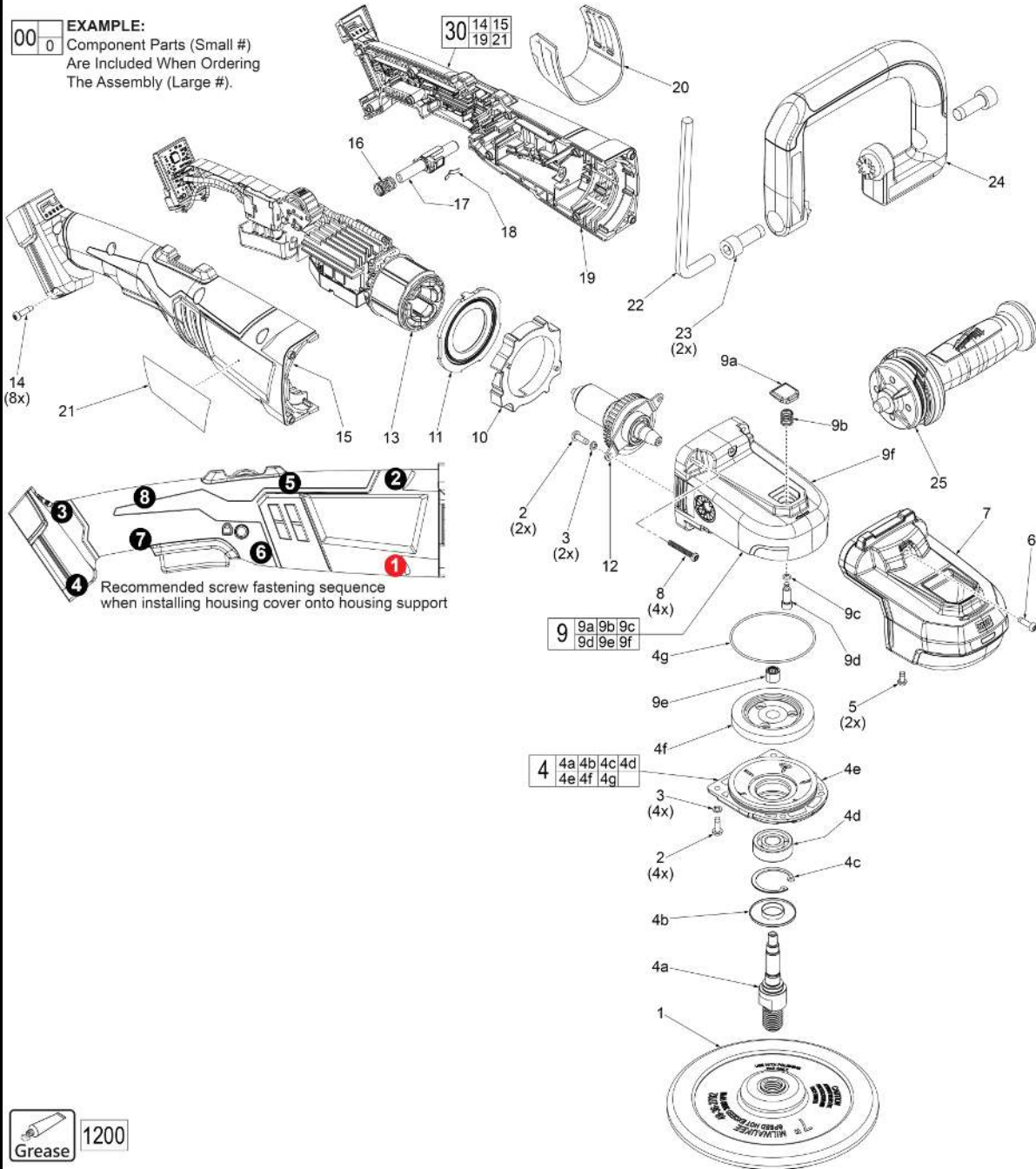



M18 FAP180

SERVICE PARTS LIST

TTI Model Number: 018 171 011, 012, 013, 014

M18 FUEL™ POLISHER

Bulletin Date:

Aug-17

Starting Serial Number:

VERSION A - L2016

ITEM	PART NUMBER	PART DISCRIPTION	QTY (PCS)
1	312048001	5" BACKING PAD	1
2	661113007	8-32 X 12MM SCREW	6
3	680866003	SPRING WASHER	6
4	203993002	SPINDLE HUB ASSEMBLY	1
4a	-	OUTPUT SHAFT	1
4b	-	DUST PROOF COVER	1
4c	633037001	RETAINING RING	1
4d	-	BALL BEARING	1
4e	-	SPINDLE HUB	1
4f	-	BEVEL GEAR	1
4g	563927001	O-RING	1
5	660852001	M4 X 8MM SCREW	2
6	660414013	M4 X 14MM SCREW	1
7	529603001	GEAR CASE SHROUD	1
8	660024035	M4 X 28MM SCREW	4
9	203995001	GEAR CASE ASSEMBLY	1
9a	529508001	SPINDLE LOCK BUTTON	1
9b	671700001	SPINDLE LOCK SPRING	1
9c	570704001	O-RING	1
9d	620705004	SPINDLE LOCK PIN	1
9e	680582005	NEEDLE BEARING	1
9f	-	GEAR CASE	1
10	529506001	BAFFLE SCROLL	1
11	529507001	BAFFLE FOOT	1
12	208123001	ROTOR ASSEMBLY	1
13	208104002	ELECTRONICS ASSEMBLY	1
14	660024030	M4 X 16MM SCREW	8
15	-	HOUSING COVER (RIGHT HOUSING)	1
16	695096001	LOCK ON-OFF SPRING	1
17	529530001	LOCK ON-OFF SHUTTLE	1
18	633852003	PLATE SPRING	1
19	-	HOUSING SUPPORT (LEFT HOUSING)	1
20	311552001	MESH FILTER ASSEMBLY	1
21	941046944	RATING LABEL	1
22	692231001	5/16" HEX KEY	1
23	660053003	M10 X 28MM BOLT	2
24	529664001	BAIL HANDLE	1
25	304057001	AVS SIDE HANDLE	1
30	203998003	HOUSING ASSEMBLY	1
31	307640030	DYNACASE ASSEMBLY	1
1200	-	TYPE Y GREASE 567G	1

TTI Model Number: 018 171 011, 012, 013, 014

Starting Serial Number:

M18 FUEL™ POLISHER

VERSION A - L2016

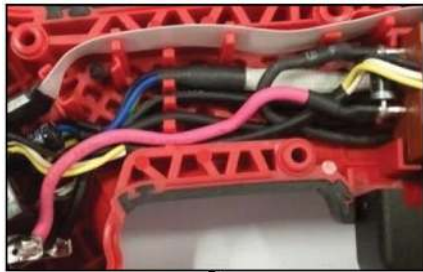

Carefully place/route ribbon cable in traps as shown.

Route all wires and wire groupings through wire traps as shown. Be sure to push wires, sleeved wire groupings and ribbon cables firmly below wire trap openings.

Avoid bending wires sharply from switch.

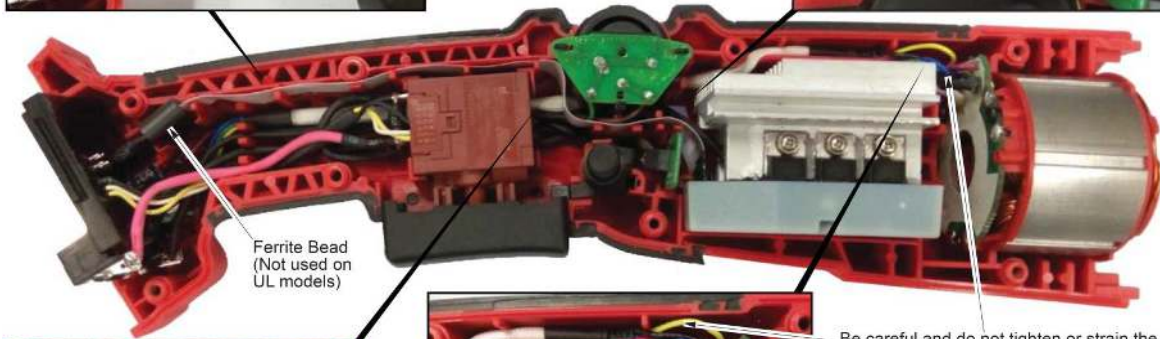
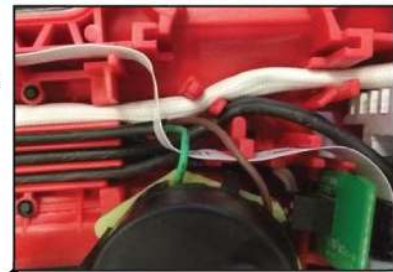

Ferrite Bead
(Not used on UL models)

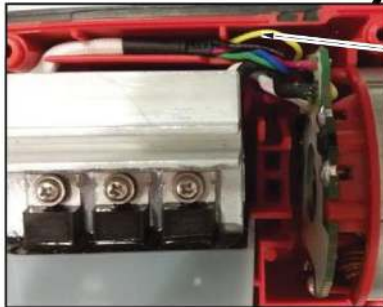

Be careful and do not tighten or strain the wires in this area.

- As an aid to reassembly, take notice of wire routing and position in wire guides and traps while dismantling tool.
- Be sure that all components of the electronics kit are seated firmly and squarely in the handle recesses.
- Avoid pinched wires, be sure that all wires and sleeves are pressed completely down in wire guides and traps.
- Prior to installing the handle cover onto the handle support, be sure that there are no interferences.

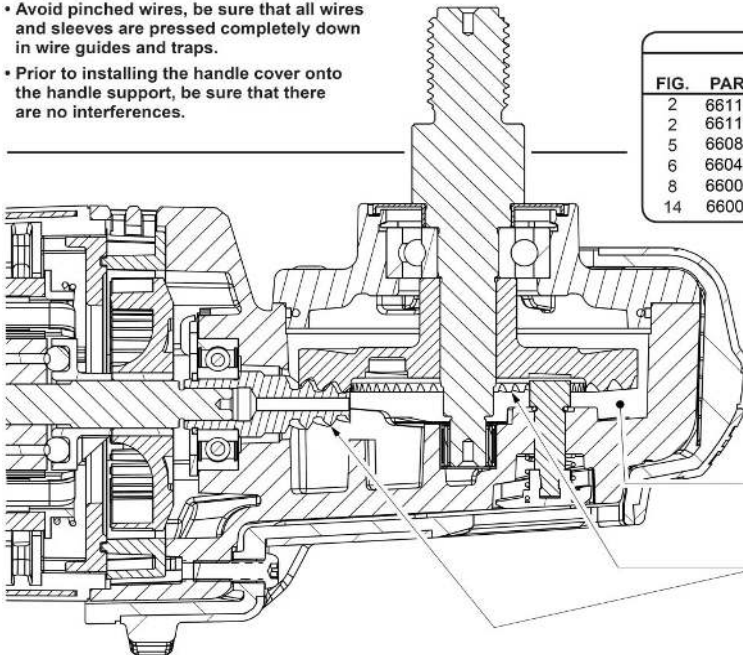

SCREW TORQUE SPECIFICATIONS

FIG.	PART NO.	WHERE USED	SEAT TORQUE	
			(KG/CM)	(Nm)
2	661113007	Spindle Hub	21.5±1.5	2.1±0.15
2	661113007	Rotor Mounting Plate	21.5±1.5	2.1±0.15
5	660852001	Gear Case Shroud	13.5±1.5	1.32±0.15
6	660414013	Gear Case Shroud	13.5±1.5	1.32±0.15
8	660024035	Gear Case	20.0±1.5	2.26±0.15
14	660024030	Housing Cover	19.0±2.0	2.15±0.15

When servicing, remove 90-95% of the existing grease prior to installing Type 'Y'. Original grease may be similar in color but not compatible with 'Y'.

LUBRICATION NOTES:

Use Type 'Y' Grease, Item 1200 (567g)

Place 18.5±1.5 grams of grease in the Gear Case cavity, around the Pinion and above and below the Bevel Gear.

Place a heavy coating of grease to the teeth of the Bevel Gear #4f and to the teeth of the Pinion Gear on the Rotor Assembly #12. Use approximately 9.0±1.0 grams of grease.